

SPRA TECHNICAL GUIDANCE S21/24

PEDESTAL SYSTEMS FOR FLAT ROOFING

WHAT IS A PEDESTAL SYSTEM?

A pedestal system is used in the construction of external floors in the commercial and residential hard landscaping sectors. The primary function of the pedestal system is to provide a raised, level surface to support the external floor layer(s).

A typical pedestal is manufactured from polypropylene. Other types manufactured from aluminium and/or other non-combustible materials can be used to comply with specific requirements of national building regulations, approved documents and technical handbooks.

'Pedestal systems' includes paving support pads – low, fixed-height pedestals used predominantly to support external access floors of concrete, porcelain or stone tiles. These are unsuitable for complex schemes where additional features are required.

Additional features could include bridging obstacles, edge retention, fully supported slope correction, height adjustment, protection of the waterproof covering, and/or wind uplift resistance. For flat roof areas of an irregular shape and/or subjected to high dead or live loads, an additional rail system may be required.



▲ PAVING SUPPORT PAD (TOP) AND ADJUSTABLE PEDESTAL

TYPICAL APPLICATIONS

A pedestal system can be used on balconies, plant areas, podia, roof terraces, walkways and winter gardens.

PERFORMANCE CHARACTERISTICS

Functional

The base of a pedestal should be circular to prevent sharp edges from puncturing the waterproof covering (warm

roof construction) and/or thermal insulation (inverted roof construction). A recommended minimum diameter is 170mm. This spreads dead and live loads across the substrate to minimise compression. Furthermore, a circular shape contributes to the efficient drainage of rainwater.

Preferably, a pedestal should have an optional locking mechanism to secure its height – particularly for taller heights and/or on a building subject to vibration such as an airport terminal or one close to a railway.

Slope correction should have a locking mechanism to fix the angle and create a safe, level walking surface for occupants. This prevents tampering, too, which can occur when accessing and/or maintaining the surface underneath the pedestal system.

Compressive Strength

Pedestals should have a minimum compressive strength >1,000kg and be tested on a full, half and quarter of a pedestal head.

External Fire Performance

BS 8579 *Guide to the design of balconies and terraces* states that a roof terrace should be designed so as not to support the spread of fire:

- onto the terrace;
- across the terrace to an adjacent structure or building; and
- across the terrace to an adjacent compartment in the same building.

A terrace (being an occupied roof) performs the function of a floor, therefore a terrace or access terrace as part of a building with an occupied floor over 11m above the lowest ground level build-up within 3m of an extensive vertical façade above may be limited to classification B_{ROOF} (t4) in accordance with EN 13501-5 *Fire classification of construction products and building elements. Part 5: Classification using data from external fire exposure to roofs tests*.

Cast stone or mineral slabs of at least 40mm thickness that constitute the top layer of a roof [terrace] assembly can be considered to fulfil all of the requirements for the performance characteristic 'external fire performance' without the need for testing in accordance with Commission Decision 2000/553/EC.

When using a flat roofing system classified in accordance with EN 13501-5 (test 4), it cannot be assumed that additional surfaces installed above the roof will achieve the same classification unless a surface finish in accordance with Commission Decision 2000/553/EC is used.

In the absence of a surface finish in accordance with the Commission Decision, a full system build-up test in accordance with DD CEN/TS 1187 *Test methods for external fire exposure to roofs (test 4)* may need to be carried out to ensure the same classification is achieved. This is especially important where the surface finish is combustible, e.g. timber decking; a roof terrace spans a compartment wall; and/or a roof is <20m from any point on a relevant boundary.

Reaction to Fire Performance

Requirement B4 of Approved Document B (AD B; as amended, for use in England) states that in buildings that include a residential purpose (purpose groups 1 and 2) with a storey 11m or more in height, balconies should only contain materials achieving class A1 or A2-s1, d0 in accordance with EN 13501-1 *Fire classification of construction products and building elements. Part 1: Classification using data from reaction to fire tests*.

Moreover, Regulation 7(2) states that building work shall be carried out so that materials which become part of an external wall, or Specified Attachment, of a Relevant Building are of European Classification A2-s1, d0 or A1. This does not apply, however, to any part of a roof... if that part is connected to an external wall.

AD B does not define the terms 'balcony' or 'terrace,' so the flat roofing industry and other relevant bodies agree that the definitions in BS 8579 should apply:

- **Balcony** Accessible external amenity platform above ground level exterior to and with direct access from a building. A balcony is formed above an external space that is not a habitable room. *For the purposes of fire, a balcony is not a roof.*
- **Terrace** External accessible surface above an internal space above ground level exterior to and with direct access from a building to occupants for purposes other than exclusively maintenance. *A terrace is a roof for the purposes of fire and waterproofing. Additionally, for fire purposes, a terrace can also perform the function of a floor.*

Practically, all components of a pedestal system installed on a balcony of a residential building with a storey 11 m or more in height, or a balcony of a Relevant Building, should achieve class A1 or A2-s1, d0. A pedestal system installed on a terrace, however, would be exempt from the requirements of Regulation 7(2) as it would constitute part of a roof. Consult the local building control body to clarify their requirements.

Note that the devolved nations of the United Kingdom (Northern Ireland, Scotland and Wales) can have different requirements. Refer to Technical Handbook E (Northern Ireland), Building Standards Technical Handbooks Section 2 (Scotland) and Approved Document B (Wales).

DESIGN CONSIDERATIONS

Blue Roofs

At the time of writing, testing of blue roofs in accordance with DD CEN/TS 1187 *Test methods for external fire exposure to roofs* and, therefore, classification in accordance with EN 13501-5 is restricted due to the limitations of available test rigs. Cast stone or mineral slabs of at least 40mm thickness that constitute the top layer of a roof [terrace] assembly can be considered to fulfil all of the requirements for the performance characteristic 'external fire performance' without the need for testing in accordance with Commission Decision 2000/553/EC. Refer to *External Fire Performance* above.

Green Roofs

There are two types of green roof construction where a pedestal system may be used:

- **Intensive** These could include, for example, flower beds; ground level podia; lawns; plazas; terraces; and raised planters.
- **Extensive** Low-maintenance planting with pedestrian access provided by paved walkways.

Thermal Insulation

In warm and inverted roof constructions, thermal insulation should have sufficient compressive strength to withstand all anticipated dead and live loads. Compression of the thermal insulation can affect the top layer of a roof terrace. Potentially, this can cause damage to paving and tiling. The base of a pedestal should be circular with a recommended minimum diameter of 170mm. This spreads dead and live loads across the substrate to minimise compression. Where dead and/or live loads are anticipated to be high, consider the use of a cover board underneath the waterproof covering and/or a rail system. Consult the supplier of the flat roofing system and/or the manufacturer(s) of its components to confirm their suitability. Refer to SPRA CQS 12 for further guidance.

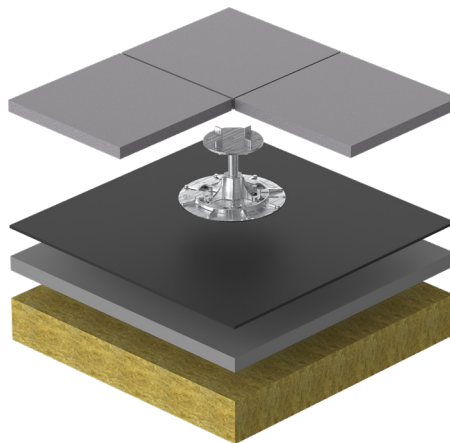

▲ OPTIONAL COVER BOARD UNDERNEATH THE WATERPROOF COVERING

In an inverted roof construction, thermal insulation should be flat and true before installing a pedestal system and external floor. Where waterproof covering sheets are lapped, thermal insulation should not rock above the lap. This rocking could transfer to the walking surface. The thermal insulation should be routed out before installation over the lap.

Protection of the Waterproof Covering

The resistance of a waterproof covering to static loading is determined by testing in accordance with EN 12730 *Flexible sheets for waterproofing. Bitumen, plastic and rubber sheets for roof waterproofing. Determination of resistance to static loading*. The principal of the test is to apply a concentrated load over a period of time, through a puncturing tool onto the surface of the membrane, when lying on a specified soft support (method A or method C) or hard support (method B). The choice of the appropriate test method for different kinds of membrane and the fields of application is defined in relevant product standards, where applicable. The relevant product standard for single ply membranes is EN 13956 *Flexible sheets for waterproofing. Plastic and rubber sheets for roof waterproofing. Definitions and characteristics*.

For the determination of resistance to static loading on soft support, Method A is typically used for sheets that do not require protective measures when mechanical loadings such as ladders, scaffoldings or other mounts are applied on them. Method C is used for sheets which require the use of a protection layer in such construction situations. Note that in accordance with EN 13956, the resistance to static loading of the sheet shall be determined in accordance with either method A or method B and shall be greater than or equal to the manufacturer's limiting value (MLV). The characteristic value is listed in a Declaration of Performance.

In high temperatures, a polypropylene pedestal may bond to the waterproof covering. To prevent this, the use of a sacrificial protection layer between the waterproof covering and pedestal base is recommended. Typically, the protection layer is specified by the manufacturer/supplier of the waterproof covering. There are two main types:

- Geotextile fleece, or
- Rubber pad (ensure compatibility).

Pedestal Layout

For grating, paving slabs, or tiling, the size and weight will dictate how many pedestals are required to spread the load. Consideration must be given to commercial or domestic loadings. There must be a pedestal underneath each corner of each grate, slab, or tile. If dimensions exceed 600mm, an additional pedestal will be required at the midpoint of each edge. A rail system can be used where loadings are excessive, for example, planters.

For decking, the joist and pedestal centres will depend upon the type (cement fibre, composite, or timber) and the intended use (commercial or domestic). Guidance should be provided by the manufacturer/supplier of the decking material.

Bridging Obstacles

It is commonplace for roof terraces to include services such as air conditioning ducts, lightning protection, rainwater outlets and ventilation systems. The placement of these services can disrupt the optimal pedestal layout, leaving areas of the external floor unsupported. In this event, a rail system should be used either locally or across the roof terrace. A rail system allows the pedestal spacing to increase. To what extent depends upon the rail system thickness, finished surface and applied loads. Consult the pedestal manufacturer for product-specific guidance.

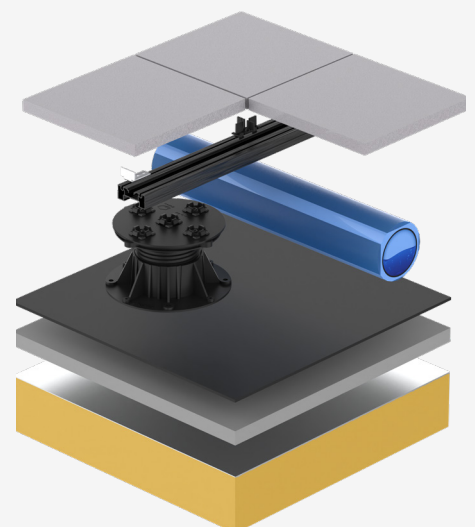

▲ RAIL SYSTEM BRIDGING PIPEWORK; OPTIONAL COVER BOARD

Rail Systems

A rail system should be manufactured from a structural material such as aluminium or timber. Non-structural material, such as plastic and wood-plastic composites, should not be used.

Acoustics and Pedestrian Comfort

Rubber membrane protection pads and/or EPDM shims can help to reduce the noise of impact on pedestals. Shims make for a more comfortable user experience under foot.

Falls

Compensation should be made for the falls of balconies and roof terraces to create a level, finished external floor. Consider the following—

- **Pedestal Height** should be adjustable to account for changing distances between the substrate and external floor layers.
- **Slope Correction** allows the external floor level to be precisely set and fixed. When using taller pedestals, it is recommended that slope correction is used at the base of the pedestal, as this ensures that the pedestal is vertical. Use a radial spirit level to determine what degree of slope correction is required.
- **Self-Levelling Pedestals** are not recommended as they rely on the weight of the external floor layers above a ball-and-socket floating head and the level cannot be fixed. Over time, this approach can contribute to instability and potential tipping of the external floor, creating a risk to pedestrians.
- **Fine Adjustment** Irregular surface finishes such as natural stone can create an uneven external floor. This can be rectified by the use of EPDM shims where the slab or tile contacts the pedestal.

Drainage

Surface water drainage from roof terraces is dependent upon gaps within the external floor layer. Regular and specific gaps between tiles can be created by the use of spacer tabs. Typical gap widths within commonly used roof covering products/materials are as follows:

- **Concrete paving** 4.50mm—5.00mm
- **GRP grating** 6.00mm
- **Natural stone** 4.50mm—5.00mm
- **Porcelain tiles** 2.00mm—3.00mm
- **Steel grating** 10.0mm
- **Timber decking** 6.00mm

Wind Uplift Resistance

Typically, cast stone or mineral slabs of at least 40mm thickness have enough self-weight to resist wind uplift. For lighter-weight layers such as porcelain tiles, currently the most common and effective solution to wind uplift is the

use of 'wind uplift discs.' These are secured to the head of the pedestals and pin down the corners of the tiles. Note that the discs resist wind uplift acting on the lightweight layers, i.e. tiles, only – not the entire flat roofing system.

When using hidden-fix systems, care must be taken to ensure that any routing out of the tile does not compromise the structural integrity of the tile and pedestal system.

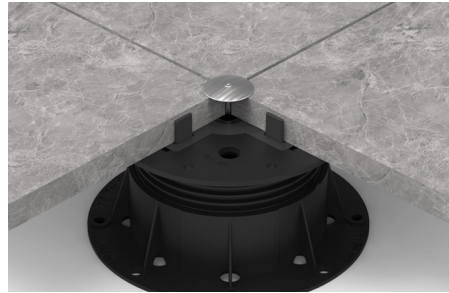

▲ WIND UPLIFT DISC USED TO SECURE LIGHTWEIGHT TILES

Access to Balconies and Terraces

BS 6229 *Flat roofs with continuously supported flexible waterproof coverings*. Code of practice states that at all abutments, the waterproof layer should be turned up to a level not less than 150mm above the adjacent finished roof system. This is fundamental to reliable detailing. However, working with building insurers and the residential sector, SPRA is aware of the requirement for unimpeded access to balconies and roof-level terraces in many designs. In this situation only, the requirement has been reduced to 75mm at the opening, provided that the following conditions are met:

- Fall to be away from the door threshold.
- Adequate outlet and overflow pipe is provided OR balcony kerb is set a minimum of 25mm below the underside of the door cill.
- The waterproof membrane extends 150mm high in the door reveal and roof/abutment wall adjacent.
- The waterproof membrane flashing extends fully up and under the door frame bottom rail and is sealed to it.
- The door threshold should have a 45mm overhang.
- A horizontal gap of minimum 10mm is maintained between frame front edge and drainage channel.
- A minimum gap of 10mm is maintained around the perimeter upstands.
- A maximum gap of 6mm is maintained between joints in the paving system.
- **Optional** Rapid removal or rainwater across the width of the opening, by including a proprietary drainage channel in front of the threshold.

Ensuring a Stable Perimeter

If the installation of the waterproof covering around the perimeter of a balcony or terrace makes access to the

edge difficult, a rail system should be used. Alternatively, a pedestal designed to be used inverted can be used.

The use of edge retainers is important as it stops tiles from 'creeping' and joints opening. This is seen often on balconies where there is lateral pressure applied by pedestrians walking through access doors.

It is not good practice to cut pedestals in order to place them closer to the edge, as this will compromise stability and structural strength.

GUARANTEE/WARRANTY

When a pedestal system is installed immediately after installation of a flat roofing system, both the flat roof and pedestal system should be guaranteed for the same time period. For example, if the flat roof were guaranteed for 10 years, the pedestal system should be guaranteed for 10 years.

Before a pedestal system is installed on an existing flat roof, the manufacturer/supplier of the original flat roofing system should be consulted and the condition of the flat roof should be assessed to ensure suitability.

RELEVANT STANDARDS AND LITERATURE

- **BS 6229** Flat roofs with continuously supported flexible waterproof coverings. Code of practice
- **BS 8579** Guide to the design of balconies and terraces
- **DD CEN/TS 1187** Test methods for external fire exposure to roofs
- **EN 12370** Flexible sheets for waterproofing. Bitumen, plastic and rubber sheets for roof waterproofing. Determination of resistance to static loading
- **EN 13501-5** Fire classification of construction products and building elements. Part 5: Classification using data from external fire exposure to roofs tests
- **EN 13956** Flexible sheets for waterproofing. Plastic and rubber sheets for roof waterproofing. Definitions and characteristics
- **Commission Decision 2000/553/EC** as regards the external fire performance of roof coverings
- **SPRA Technical Guidance S01/20** Design Guide for Single Ply Roofing
- **SPRA Technical Guidance S20/23** Junctions of Compartment Walls with Flat Roofs
- **SPRA Component Quality Standard 04** Stone Mineral Wool Insulation Boards for Flat Roofing
- **SPRA Component Quality Standard 12** Gypsum Boards with Mat Reinforcement for Flat Roofing
- **SPRA Component Quality Standard 13** Pedestal Systems for Flat Roofing
- **The GRO Green Roof Code** The Green Roof Organisation (GRO)

Refer to the latest versions unless otherwise stated.

SINGLE PLY ROOFING ASSOCIATION

Unit 26 Coney Green Business Centre, Wingfield
View, Clay Cross, Derbyshire, S45 9JW

✉ technical@spra.co.uk
☎ 0845 154 7188
🌐 www.spra.co.uk

📷 @singleplyroofing
🌐 The Single Ply Roofing Association (SPRA)
🐦 @singleply